

DUPERON® FLEXRAKE® FSB

FINE SCREEN BOUTIQUE



The FlexRake Fine Screen Boutique (FSB) provides a robust all-inclusive system for simple, affordable, and reliable automated bar screening for small food and beverage applications. It incorporates proven Duperon Adaptive Technology™ specifically designed for boutique applications and price point, maximizing value and performance.

THE DUPERON DIFFERENCE

REDUCES TREATMENT COSTS

- *Effective fine solids removal lowers BOD (biological oxygen demand), the amount of treatment chemicals needed, debris loading on downstream processes or surcharges for high-strength wastewater*

BOTTOM-LINE COST SAVINGS

- *With few parts, minimal maintenance, and long product life, the FSB is easy to install, own, and operate*

FLEXIBLE DESIGN

- *Adapts to a range of site conditions for debris and flow process peaks, eliminating the need for graduated screens*

EFFICIENT

- *Uses fractional horsepower consumption and no process water requirements*

DESIGNED FOR DUTY

- *Pre-engineered to perform in flows, conditions, and price point for boutique wineries and other industrial applications*

DUPERON® FLEXRAKE® FSB

PROVEN STANDARD OF SIMPLICITY

In 1995, Duperon invented the FlexRake and transformed the water and wastewater industry

ADAPTIVE TECHNOLOGY

The FlexRake FSB is a front-clean, front-return, mechanically cleaned fine bar screen in a pre-engineered packaged 2 ft x 4 ft stainless steel tank. Duperon developed it specifically to reduce treatment costs for the low flows found in the boutique wine industry. The FlexRake FSB is a simple alternative to drum screens when water usage and/or costs are prohibitive.

HOW THE FLEXRAKE WORKS



1 The FlexLink™ articulates to a 90 degree angle, closing on the drive pin. Once closed, the sprocket drives the link system forward.



3 The FlexLink™ forms its own rotating framework at the bottom of the channel.



2 As it leaves the drive sprocket, the FlexLink™ locks into a solid bar, forming its own frame.

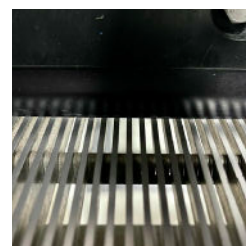

4 Scrapers remove debris from the face of the wedgewire screen.

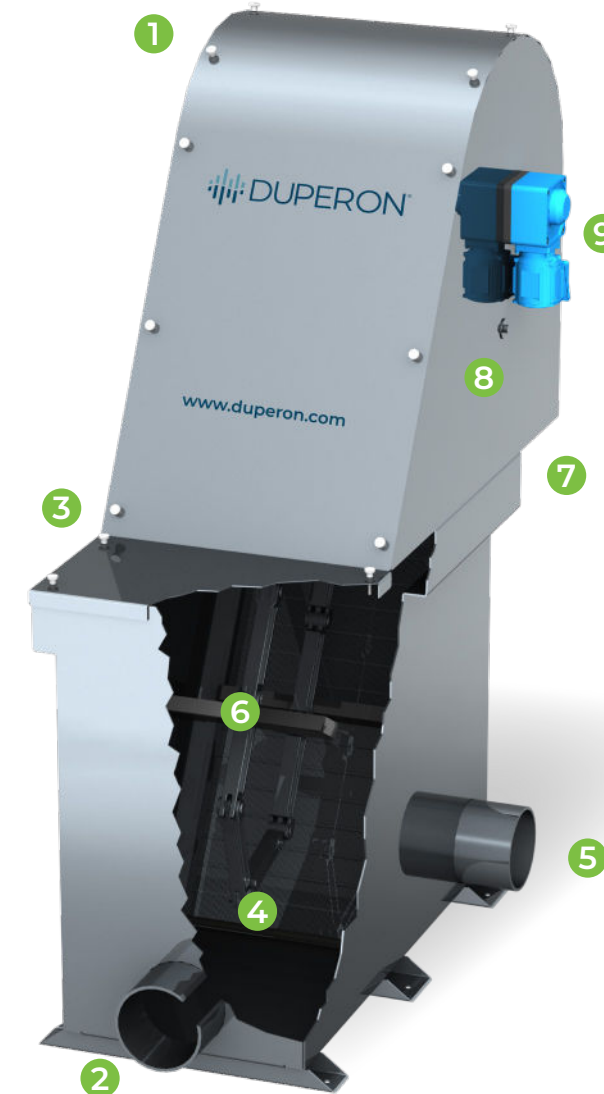

FLEXRAKE® FSB FEATURES

- 1** Pre-engineered solution reduces costs and lead times
- 2** Plug and play: pipe-in, pipe-out eliminates plumbing, pumping and other infrastructure modifications
- 3** Compact system includes stainless steel tank, built-in overflow bypass, enclosure, and controls
- 4** Industry-leading FlexLink™ eliminates lower sprockets, submerged bearings, and tracks
- 5** No process water required
- 6** Long product life with use of SSSL and UHMW-PE durable materials
- 7** Low maintenance
- 8** Flexible design adapts to planned process peak variations as well as unexpected debris
- 9** Energy efficient: uses fractional horsepower motor

WEDGEWIRE FINE SCREENING

HIGH-QUALITY EFFLUENT FLOWS TO THE BOTTOM LINE

Duperon helps customers achieve a high-quality effluent and reduces operating expenses in food and beverage wastewater processing.

- It begins with simple, reliable screening that handles the unique conditions of your plant, with minimal downtime or maintenance.
- By removing the bulk of the solids loading, it allows the downstream treatment processes to operate as they should; problem-free, reducing costs and ensuring uninterrupted production.
- Screening improves the efficiency of process water treatment to meet regulations, product quality demands and maintain environmental compliance.
- All of which allows you to focus your resources on production rather than treatment.

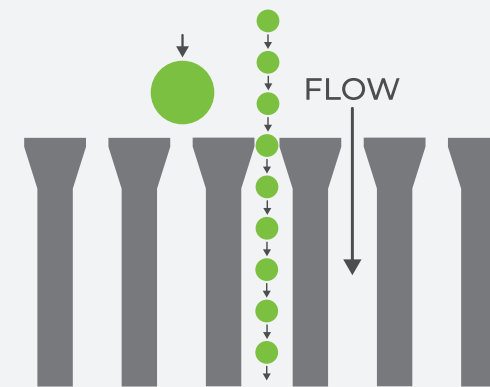

B6 PROFILE WEDGEWIRE

Duperon utilizes the "B6 profile" for its increased column strength while maximizing open area for flow between bars.

Due to the B6 Profile wedgewire bars, large items are captured at the face of the bar screen to be removed by a scraper. Smaller debris passes through without getting lodged between bars.

FLEXRAKE® FSB TANK DIMENSIONS

A Tank height	3 ft - 8 in
B Tank width	2 ft
C Tank length	4 ft - 5 in
D Discharge height	3 ft - 5 in
Screening area	9.6 sq ft
Inlet/outlet pipe diameter	8 in

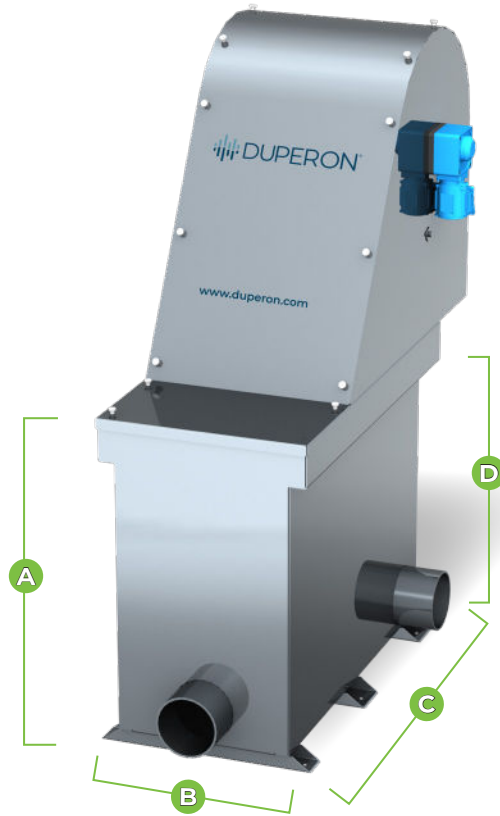

PRODUCT DATA

DISCHARGE HEIGHT	3 ft 5 in
LIFTING CAPACITY	300 lbs
WEDGEWIRE SCREEN OPENINGS	0.020 in, 0.040 in, 0.060 in, 0.100 in, or 0.125 in
ANGLE OF INSTALLATION	30 degrees from vertical
MATERIALS OF CONSTRUCTION	Available in 304 or 316 SSTL
SCRAPER CONFIGURATION	UHMW scrapers consist of beveled edges, squeegees, or brushes depending on application
TYPICAL MOTOR	¼ HP 1 PH, 115/230 VAC OR 3 PH, 230/460 VAC, weatherproof motor
CLEANING FREQUENCY	1 discharge/minute
FLOW CAPACITY	Dependent on screen opening and application
STANDARD CONTROLS	Overload protection, variable speed, discrete start/stop
TYPICAL APPLICATIONS	<ul style="list-style-type: none"> • Wineries • Food processing plants • Other low flow, fine screening industrial applications

NOTE: The FlexRake FSB is a pre-engineered product line, however, Duperon Corporation has engineered-to-site options available.